

12 Zasuwa nożowa - Knife gate valve - Robinet-vanne à montage entre brides

12.02 EX

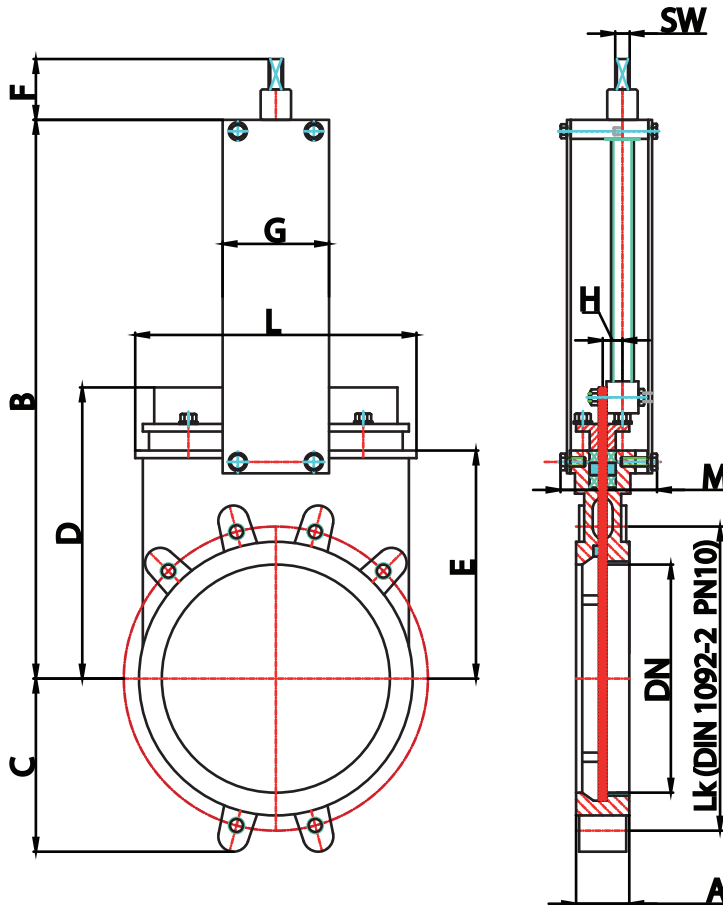

DN	A	B	C	D	E	F	G	H	SW	L	M
50	40	280	63	170	105	50	80	12	19	119	90
65	40	285	70	183	115	50	80	12	19	134	90
80	50	307	92	184	124	50	80	12	19	149	90
100	50	345	106	202	140	50	80	12	19	169	90
125	50	390	120	211	150	50	80	16,4	19	180	104
150	60	430	130	241	175	50	80	16,4	19	210	104
200	60	538	160	288	205	50	140	20	19	262	118
250	70	655	198	345	250	50	140	20	19	318	118
300	70	745	234	395	300	50	140	22	27	372	118
350	96	860	258	430	338	100	150	22	27	431	193
400	100	965	292	480	392	100	150	26	27	486	193
450	106				432	100	150	26	27	540	197
500	110	1185	340	592	485	100	150	38	27	602	197
600	110	1420	400	705	590	100	140	38	27	708	197
700	110	1675	452	787	760	120	140	30	27	834	400
800	110	1890	505	901	795	120	140	30	27	1015	320
900	110	2115	555	1024	900	120	140	35	27	1040	320
1000	110	2340	610	1108	980	190	140	35	27	1150	320

12 Zasuwa nożowa · Knife gate valve · Robinet-vanne à montage entre brides

Werkstoffe Material Matériau

Korpus Body Corps	GG 25 (EN JL 1040)	GGG 40 (EN JS 1030)	1.4408
Płyta Plate Plaque	1.4301	1.4571	
Trzpień Spindle Tige	1.4104	1.4305	1.4571
Zabezpieczenie powierzchni Coating Traitement de couche	EKB powłoka RAL 5007 ca. 200µ EKB coated RAL 5007 ca. 200µ revetue de EKB RAL 5007 ca. 200µ		
Uszczelka Seal Composé	EPDM/APTK; na zapytanie: Viton, Teflon EPDM/APTK; on request: Viton, Teflon EPDM/APTK; sur demande: Viton, Teflon		

Połączenie kołnierzowe dla BAP - Zasuwa nożowych wg EN 1092-2, owiert wg PN 10

Flange connection for BAP - knife gate valves according to EN 1092-2, drilled PN 10

Raccord à bride por robinet-vanne à montage entre brides EN 1092-2, percé selon PN 10

DN 50 - 65

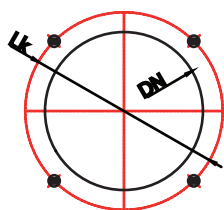

DN 80 - 200

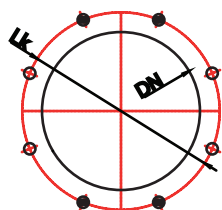

DN 250 - 300

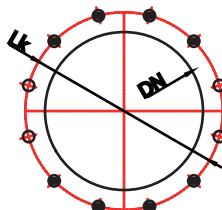

DN 350 - 400

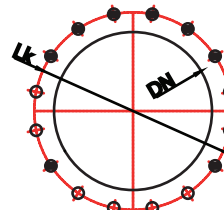

DN 450 - 600

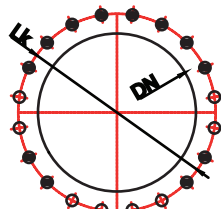

DN 700 - 800

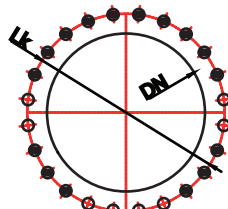

DN 900 - 1000

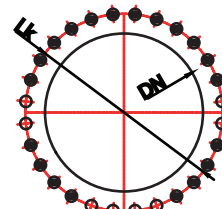

DN 1200

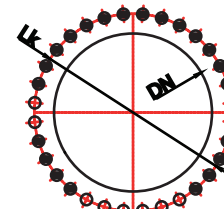

Średnica podziałowa kołnierzy wg EN 1092-2, owiercone wg PN 10

Bolt circle for flange according to EN 1092-2, drilled PN 10

Cercle des trous de boulons à montage entre brides EN 1092-2, percé selon PN 10

DN	50	65	80	100	125	150	200	250	300	350	400	450	500	600	700	800	900	1000	1200
k	125	145	160	180	210	240	295	350	400	460	515	565	620	725	840	950	1050	1160	1380
N	4	4	8	8	8	8	8	12	12	16	16	20	20	20	24	24	28	28	32
Nr	4	4	4	4	4	4	4	6	6	10	10	14	14	14	16	16	20	20	22
Np			4	4	4	4	4	6	6	6	6	6	6	6	8	8	8	8	10
M	16	16	16	16	16	20	20	20	20	20	24	24	24	27	27	30	30	33	36
t	11	11	11	11	11	14	14	18	18	22	24	24	24	24	20	20	20	20	30

N = Całkowita liczba otworów - Total numer of holes - Total de trous

NR = Liczba otworów z gwintem, nieprzelotowych - Number of blind holes with thread - Nombre de a trous à sacs avec filet

Np = Liczba otworów przelotowych - Nuber of through holes - Nomber des trous par marchant

t = Głębokość otworów z gwintem, nieprzelotowych - Blind holes depth - Profondeur des trous à sacs